



# Americ Corporation

## OWNER'S MANUAL

SAFETY INSTRUCTIONS ENCLOSED

***Please Read & Keep These  
Instructions with the Fan***



## VAF-3000

For use in Non-Explosive/Non-Flammable environments only

Purchase Date \_\_\_\_\_ Serial No. \_\_\_\_\_  
Dealer \_\_\_\_\_

*Americ Corporation* 785 Bonnie Lane • Elk Grove Village, IL 60007 • USA  
Phone: (847) 364-4646 • Fax: (847) 364-4695

## **AMERIC LIMITED WARRANTY**

If you are the original purchaser of a new Americ Vane Axial Fan, then you are entitled to a limited warranty subject to the terms and conditions set forth herein. To qualify for the limited warranty you must complete the enclosed registration card and mail it to Americ within (30) days of the purchase so that there is a record of your purchase. Americ's limited warranty is for the replacement or repair of any part that proves to be defective in workmanship or materials for a period of one (1) year from the date of purchase by the original purchaser. During the first year, Americ will provide all parts necessary to correct any defects, free of charge. This limited warranty extends only to the original purchaser who retains ownership of the Fan. This limited warranty is not transferable to any subsequent purchaser or second-hand user.

The limited warranty extends only to the repair or replacement of parts found upon Americ's examination to be defective. Unless any part or assembled unit replaced hereunder is returned, freight pre-paid, together with a letter describing the problem to Americ or an authorized Americ dealer, this limited warranty will be void and of no effect.

This warranty is limited to ninety (90) days for labor from the date of the purchase. Thereafter, any labor costs incurred will be charged to the customer at the prevailing hourly rate.

This limited warranty shall not extend to a product that has been used in an improper manner, or that has been disassembled, altered or improperly maintained. Nor shall this limited warranty apply if the Fan has been subjected to corrosive chemicals, improper voltage, unauthorized repairs, fire, flood, abnormal wear or any causes beyond Americ's control.

This limited warranty does not apply if the serial number has been removed, obliterated, or defaced.

Americ Corporation reserves the right to make changes to the Vane Axial Fan in design, materials or specifications as necessary and without prior notice. Americ shall not be obliged to make alterations or modifications to existing products previously manufactured.

To obtain replacement parts pursuant to this limited warranty, you must write to Americ or call (847) 364-4646 to receive an authorization number.

Replacement parts will not be provided unless the customer first provides the serial number of the Fan and also receives an authorization number from Americ.

OTHER THAN THE FOREGOING LIMITED WARRANTY, THERE ARE NO FURTHER WARRANTIES OR ANY AFFIRMATIONS OF FACT OR PROMISES BY AMERIC WITH RESPECT TO THE VANE AXIAL FAN. THE DURATION OF ANY IMPLIED WARRANTIES ARE LIMITED TO THE TERMS OF THE ABOVE LIMITED WARRANTY. SOME STATES DO NOT ALLOW LIMITATIONS ON HOW LONG AN IMPLIED WARRANTY MAY LAST, SO THE ABOVE LIMITATIONS MAY NOT APPLY TO YOU. WITHOUT LIMITING THE GENERALITY OF THE FOREGOING, AMERIC EXPRESSLY DISCLAIMS ANY INFRINGEMENT OR ANY AFFIRMATIONS OF FACT OR QUALITY NOT EXPRESSLY CONTAINED HEREIN. AMERIC CORPORATION AND ITS AFFILIATED NEITHER ASSUME NOR AUTHORIZE ANY PERSON TO ASSUME FOR THEM ANY OTHER OBLIGATION OR LIABILITY IN CONNECTION WITH ITS PRODUCTS. THERE ARE NO OTHER WARRANTIES WHICH EXTEND BEYOND THE DESCRIPTION ON THE FACE HEREOF. IN NO EVENT SHALL AMERIC CORPORATION BE LIABLE FOR SPECIAL, INCIDENTAL OR CONSEQUENTIAL DAMAGES, OR FOR LOSS OF PROFITS OF ITS CUSTOMERS OR USERS OF PRODUCT. SOME STATES/JURISDICTIONS DO NOT ALLOW THE EXCLUSIONS OR LIMITATIONS OF INCIDENTAL OR CONSEQUENTIAL DAMAGES, SO THE ABOVE LIMITATIONS MAY NOT APPLY TO YOU. THIS LIMITED WARRANTY GIVES YOU SPECIFIC LEGAL RIGHTS, AND YOU MAY ALSO HAVE OTHER RIGHTS WHICH VARY FROM STATE TO STATE.

## **INTRODUCTION**

**Congratulations...**on your selection of a new Vane Axial Fan from Americ Corporation. Our goal is to provide you with the very best in high performance air ventilators. Reading this Owner's Manual will help you achieve the maximum benefit from your portable air ventilator. If you do not understand any portion of this Manual, please contact Americ, or your authorized Americ dealer for proper assistance prior to operating this Fan.

Do not allow anyone to operate the Vane Axial Fan without first reading the Operator's Manual and becoming familiar with its operation. Americ has endeavored to provide you with the finest equipment available for providing air for portable ventilation purposes. The possibility does exist, however, that the Vane Axial Fan can be subjected to applications not intended by Americ. **Misuse and/or misapplication of the Vane Axial Fan can lead to the possibility of serious damage, injury or even death.** Anyone operating the Vane Axial Fan should refer to current OSHA job safety and health rules and regulations pertaining to the construction industry, with a particular emphasis on 29 CFR 1910, which contains rules governing Permit-Required Confined Spaces for General Industry.

Record the Vane Axial Fan model and serial number in the space provided below.

Model No. \_\_\_\_\_ Serial No. \_\_\_\_\_ Date Purchased \_\_\_\_\_

All specifications are general in nature and are not intended for specific application purposes. Americ accepts no responsibility for variations which may be evident in actual products, specifications, pictures and descriptions contained in this publication.

## **SAFETY PRECAUTIONS**



### **DANGER**

THE FAN IS DESIGNED FOR PORTABLE AIR VENTILATION PURPOSES ONLY. THE FAN IS NOT DESIGNED FOR TRANSPORTING LIQUID OR SEMI-SOLID MATERIALS. **THE ELECTRIC MOTOR AND FAN HOUSING ARE NOT DESIGNED FOR OPERATION IN AN EXPLOSIVE OR FLAMMABLE ATMOSPHERE. OPERATION OF THE FAN IN AN EXPLOSIVE OR FLAMMABLE ATMOSPHERE MAY RESULT IN PROPERTY DAMAGE, PERSONAL INJURY OR EVEN DEATH.** INCORRECT USE OF THE FAN CAN RESULT IN AN ELECTRICAL SHOCK AND/OR ELECTROCUTION. ALWAYS OPERATE THE FAN IN COMPLIANCE WITH CURRENT OSHA AND NATIONAL ELECTRIC CODE REGULATIONS.



### **DANGER**

INCORRECT USE OF THE FAN CAN RESULT IN PROPERTY DAMAGE, PERSONAL INJURY OR EVEN DEATH. TO REDUCE THIS RISK, GIVE COMPLETE AND UNDIVIDED ATTENTION TO THE JOB AT HAND. AN ENVIRONMENT ATMOSPHERE CONSTANTLY CHANGES. THEREFORE, IT'S RECOMMENDED THAT AIR MONITORING/ GAS DETECTION EQUIPMENT BE USED FREQUENTLY. IF TESTS SHOW THAT THE ATMOSPHERE QUALIFIES AS A **HAZARDOUS LOCATION** (AN AREA WHERE THE POSSIBILITY OF EXPLOSION AND FIRE IS CREATED BY THE PRESENCE OF COMBUSTIBLE LIQUIDS, FLAMMABLE GASES, VAPORS, DUST, FIBERS, FLAMES OR FILINGS.) **DO NOT USE THIS FAN.** READ AND UNDERSTAND THE FOLLOWING PREPARATION ITEMS AND GENERAL SAFETY INFORMATION.

### **PREPARATION**

- 1) Become familiar with the Fan operations before utilizing this Fan. Read and understand all Cautions and Warnings in this Manual. Refer to current OSHA publications for complete job safety and health rules and regulations (CFR 1926 and 1910).
- 2) Confirm that the Fan is in its original, factory configuration and has not been modified in any manner.

- 3) Minors should not be allowed to operate the Fan. Close attention is necessary when used, especially when used near children or animals.
- 4) Guard against the possibility of back-related injuries. Always lift the Fan with leg muscles and not with the back.
- 5) Periodically inspect the Fan visually for damaged or worn parts. Check for loose and/or broken parts. Be sure that the Fan and accessories are in good working condition before operating.
- 6) Ground the motor securely . The (U.S.) Fan utilizes a NEMA 5-15P plug. It is designed to operate ONLY from a grounded, 115 volt nominal AC~, 60Hz, single phase power source that utilizes a NEMA 5-15R receptacle. The use of a ground fault circuit interrupter (GFCI) gives additional on the job protection from electrical shock hazards caused by ground faults in commercial, industrial and residential applications.
- 7) Know how to stop the Fan quickly in an emergency. Turn unit off at (on/off) switch located on side of unit or unplug Fan from power supply.

### **GENERAL SAFETY INFORMATION**

- 1) Never place the Fan in standing water because of extreme shock hazard.
- 2) Never allow air intake grill to become blocked.
- 3) Never discharge flammable solvents or kerosene based chemicals through the Fan air intake grill.
- 4) **Do not use the Fan in areas where flammable or combustible liquids, gases, vapors, dust, fibers, or filings may be present.**
- 5) Never put any object in the air intake grill.
- 6) Never run the Fan outside when it is raining. Never store the Fan outdoors.
- 7) Do not use the Fan as a toy.
- 8) Use the Fan only with a properly grounded outlet.
- 9) Unplug the Fan from outlet when not in use and before servicing.

**WARNING: To reduce the risk of fire or electric shock, do not use this fan with any solid state speed control device.**

**GENERAL SAFETY INFO. (CONT'D)**

10) Do not use the Fan with a damaged cord or plug. Do not pull or carry the Fan by its cord, do not use cord as a handle, do not close a door on the cord, and do not pull cord around sharp edges or corners. Keep cord away from heated surfaces. Do not unplug the Fan by pulling on cord, grasp the plug and not the cord. Do not handle the plug or cord with wet hands.

11) Keep hair, loose clothing, fingers, and all parts of the body away from the air intake grill.

12) Do not allow water inside the motor. If the motor becomes wet for any reason, unplug the Fan and thoroughly dry it before using again.

13) Never remove the ground from the power cord or plug, as this may result in electrical shock or electrocution. Removing the ground would void the warranty.

14) If the Fan has been dropped, left outdoors, or dropped into water, etc..., please thoroughly inspect it prior to use. If the Fan is not working or if you have a question about its safe operation, do not operate it. Contact an Americ Fan Authorized Service Center, or Factory direct at (847) 364-4646. [www.americ.com](http://www.americ.com).

**OPERATION**

1) Your new Fan comes to you completely assembled and ready to operate. Upon removing the Fan from its carton, inspect it for any possible damage in transit.

2) Before operating the Fan, please read all the safety Precautions and General Safety Information about the proper and safe use of the Fan.

3) Assess your job site, certain job site locations are classified as being hazardous because the atmosphere may contain gas vapor or dust in explosive quantities.

 **DANGER THE ELECTRIC MOTOR AND FAN HOUSING ARE NOT DESIGNED FOR OPERATION IN AN EXPLOSIVE AND/OR FLAMMABLE ATMOSPHERE OF ANY CLASS OR GROUP. OPERATION OF THE FAN IN AN EXPLOSIVE OR FLAMMABLE ATMOSPHERE MAY RESULT IN PERSONAL INJURY OR DEATH.**

4) Locate a properly grounded outlet.

5) Prior to plugging in the Fan into a grounded outlet, inspect the inlet and outlet grills and remove debris

which may restrict airflow movement. Never operate the Fan without the inlet and outlet grills properly secured and in place. Never replace the grills with other than factory supplied replacement units.

6) Note the directional airflow indicator on the external shell. This is the way the air moves.

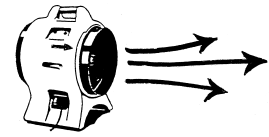

7) Place the Fan on secure footing to prevent it from shifting while in use.

8) Do not stand directly in front of and/or face the Fan outlet. Personal injury can result from being struck by debris thrown at a relatively high velocity from the Fan blade.

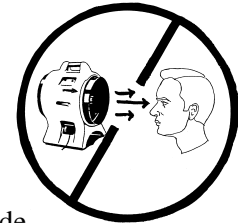

9) When ducting is required, do not install duct while Fan is in operation. Place duct lip over the Fan duct adapter, secure firmly, and note direction of the airflow.

10) When duct is used, be aware that the airflow rate decreases as the length of duct increases. Airflow rates will vary with specific duct types and manufactures.

11) Position Fan air inlet away from walls and other obstructions to allow for maximum air intake

12) **For safe operation, use the Fan only in combination with thorough gas detection tests and continual retesting.**

 **DANGER**

**ALWAYS ASSUME A CONFINED SPACE WORK AREA IS CONTAMINATED UNTIL IT HAS BEEN PROVEN SAFE FOR WORK PERSONNEL. NEVER ENTER A CONFINED SPACE WORK AREA UNTIL IT HAS BEEN THOROUGHLY TESTED WITH APPROPRIATE GAS DETECTION EQUIPMENT AND PROVEN SAFE FOR WORK PERSONNEL.**

## MAINTENANCE



### **DANGER**

**ALWAYS SHUT OFF THE FAN AND UNPLUG IT FROM ITS POWER SOURCE TO PREVENT ACCIDENTAL STARTING AND THE POSSIBILITY OF ELECTRICAL SHOCK AND/OR ELECTROCUTION. BE SURE THE FAN BLADE HAS STOPPED ROTATING BEFORE PLACING ANY OBJECTS OR FINGERS NEAR THE FAN GRILL.**

1. Visually check all fasteners and individual components for loose or broken parts. Tighten or replace items, as required, only with genuine, factory approved replacement parts.

2. Keep the Fan blade clean from debris. Accumulation of dust, dirt, paint, etc. on the Fan blade will throw the blade rotation out of balance resulting in damage. To clean the Fan blade, be sure the plug is disconnected and the blade has stopped rotating. Remove one grill and wipe blade and interior shell housing clean of debris with a damp cloth and mild liquid soap. Dry all parts thoroughly. **DO NOT PRESSURE WASH THE FAN.** Replace grill prior to next operation.



### **DANGER**

**DO NOT OPERATE THE FAN WITHOUT THE INLET AND OUTLET GRILL PROPERLY IN PLACE.**

3. Contact an Americ Authorized Service Center, or Americ directly for Fan maintenance or repair not described in this manual (or if you are unsure whether maintenance is required.) at Tel# (847) 364-4646, or at [www.americ.com](http://www.americ.com).

## SERVICE

1) Refer to the TROUBLESHOOTING GUIDE in this Manual.

## MOTOR SPECIFICATIONS

	<b>A</b>	<b>B</b>
Voltage	110V AC~	230V AC~
Frequency	50/60 Hz	50Hz
Phase	Single	Single
Electric Motor	1 HP	1 HP (.75kw)
Current (amps)	6/7.1	4.2
R.P.M	3425	2850
Watts	615W@110V	670W@230V
Free Air (cfm)	2091	2000 (57m3)
Max S.P.	3"	2.5" (68mm/aq)

## GENERAL INFORMATION & DIMENSIONS

Type	Axial	
Duct adapter	12" dia.	(30 cm)
Height	21"	(53.34 cm)
Width	14"	(35.65 cm)
Length	17"	(43.18 cm)
Weight	32.5 lbs	(14.74 kg)

## AIR FLOW RATES

<u>Feet</u>	<u>Description</u>	<u>(110V AC)</u>		<u>(230V AC)</u>	
		<u>CFM</u>	<u>M<sup>3</sup>/Min.</u>	<u>CFM</u>	<u>M<sup>3</sup>/Min.</u>
	Free Air	2091	59	2000	56.6
15' duct	Straight	1756	50	1700	48.1
15' duct	1-90° bend	1637	46	1400	39.6
25' duct	Straight	1734	49	1650	46.7
25' duct	1-90° bend	1550	44	1250	35.4
25' duct	2-90° bends	1498	42	1245	35.2
100' duct	Straight	1361	39	1125	31.8

Flow rates were third party tested in a chamber built in accordance with AMCA STD. 210-85. The published flow rates are intended to serve only as a reference. Manufacturing tolerances, duct type, and specific operating parameters will affect the overall flow rates(s) for each particular Fan.



### **CAUTION**

**THE AIR FLOW RATE DECREASES AS THE LENGTH OF DUCT INCREASES FOR BOTH BLOWING AND SUCTION APPLICATIONS. AIR FLOW RATES WILL VARY WITH SPECIFIC DUCT TYPES AND MANUFACTURES.**

# VAF 3000 PICTORIAL BREAKDOWN

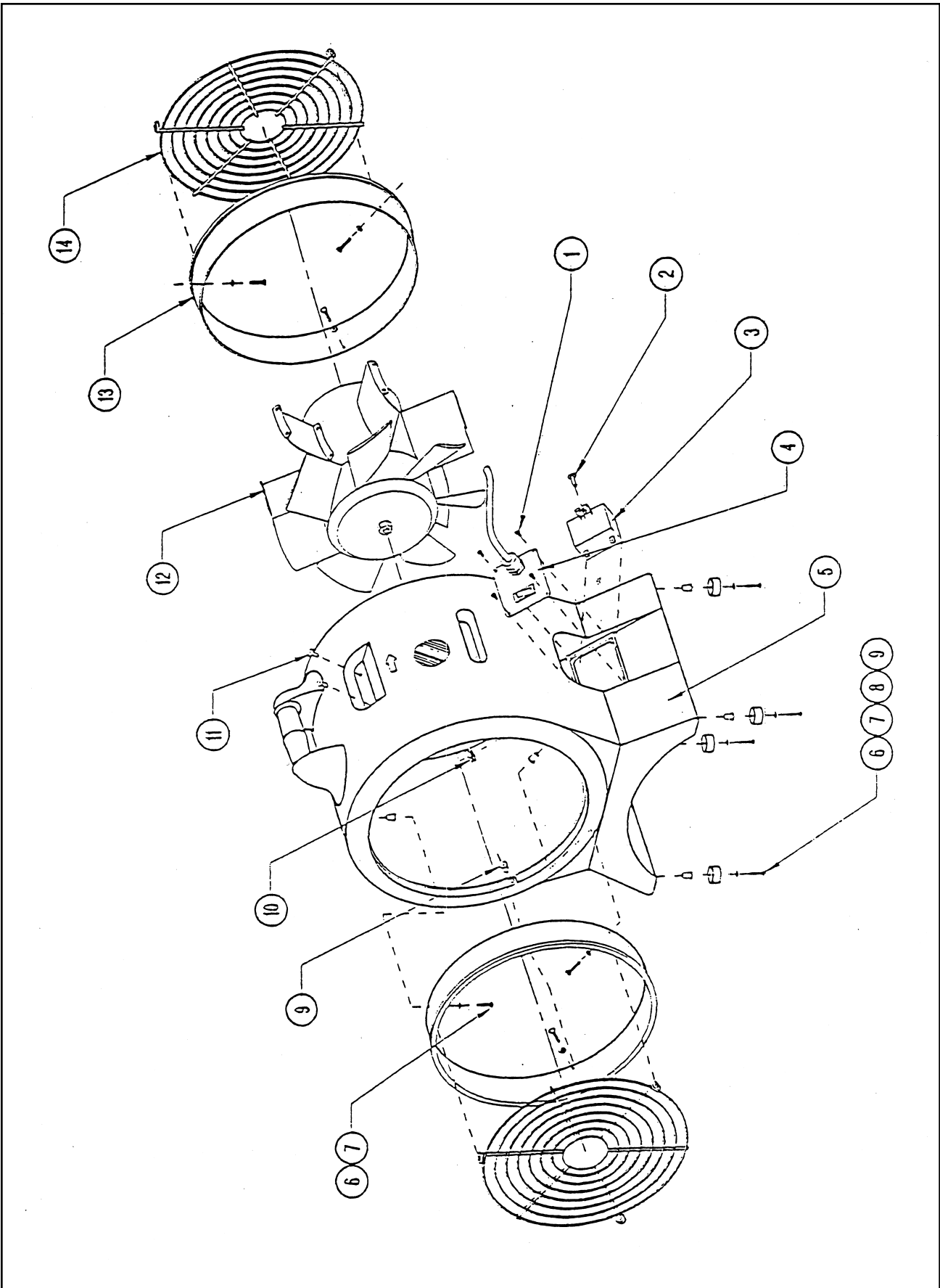



## AMERIC AXIAL FAN TROUBLE SHOOTING

**CAUTION:** All service procedures should be executed with the unit unplugged.

Item	Part#	Each	Description
1	03-00566A	1	Screw (#6-3/8 SS Phil Pan HD)
2	03-00983A	1	Rivet (5/32" Alum Blk Ano Peel)
3	02-00877A	1	Capacitor (115V/60HZ)
4	19-01046	1	Switch Kit
	02-00007	1	20' Cord (20' 16/3 w/grip)
	02-00974A	1	Cord Strain Relief
	02-00976A	1	Switch (Rocker w/Splashguard)
	09-00966A	1	Switch Plate
5	10-01063A	1	Shell (Blue)
6	03-01040	1	Bolt (SS M3x.5x20MM HH MS)
7	03-01173	1	Washer (#6 SS)
8	13-00964A	1	Rubber Foot (15/16x.625 Blk)
9	03-00979A	1	Nut, well (M3x.5 E632)
10	02-01017A	1	Grommet, rubber (#896)
11	03-00030	1	Rivet (3/16 Alum Blk Ano Lg)
12			Motor (Assembly Parts)
	02-00874A	1	Motor (1 HP 100V 50/60HZ)
	03-00505	1	Nut (3/8-16 SS Nyloc)
	03-00506	1	Washer (3/8"x1.37x.062 SS Flat)
	03-00962A	1	Screw (8-32x1/4" HWH)
	09-00889A	1	Vane
	17-00852A	1	Fan Blade (Bushing included)
13	10-01064A	1	Duct Connector (12")
14	09-00879A	1	Grill

230 Volt parts, and other colored shells			
15	02-01160	1	Motor (230V/50HZ)
16	02-01172	1	Cord (230V/50HZ)
17	02-01183	1	Capacitor (230V/50HZ)
18	03-00983A	1	Rivet (5/32")
19	03-01184	1	Clamp (Capacitor)
20	19-01046-01	1	Switch Cord Kit (230V/50HZ)

(Refer to item # on pictorial breakdown)

### UNITED KINGDOM CORDS ONLY

#### WARNING

**THIS APPLIANCE MUST BE EARTHED IMPORTANT**

The wire of this mains lead are colored in accordance with the following code:

BLUE — NEUTRAL  
 BROWN — LIVE  
 YELLOW/GREEN — EARTH

As the colors of the wires in the mains lead of this appliance may not correspond with the colored markings identifying the terminals in your plug proceed as follows: The wire colored brown must be connected to the terminal marked with the letter -L- or colored red.

The wire colored blue must be connected to the terminal marked with the letter -N- or colored black.

The wire colored yellow/green must be connected to the terminal marked with the letter E or . Ensure that your machine is connected correctly. If you are in any doubt consult a qualified electrician.

This appliance must be protected by a 13A fuse if a 13A (B.S. 1363) plug is used or, if any other type of plug is used, by a 5A fuse either in the plug or adapter or at the distribution board.

PROBLEM	CAUSE	SOLUTION
Unit will not run.	<ol style="list-style-type: none"> <li>1. No power to unit.</li> <li>2. Switch not on.</li> <li>3. Switch is faulty.</li> <li>4. Faulty/broken cord or motor wire.</li> </ol>	<ol style="list-style-type: none"> <li>1. Plug unit in. Check circuit breaker.</li> <li>2. Place in "ON" position.</li> <li>3. Replace switch.</li> <li>4. Perform continuity check, using volt/amp meter. Repair/replace faulty/broken wire.</li> </ol>
Unit runs but fan makes loud scraping noise.	<ol style="list-style-type: none"> <li>1. Unit has been severely jolted causing fan to rub against housing.</li> <li>2. Unit has been severely jolted causing housing to deform.</li> </ol>	<ol style="list-style-type: none"> <li>1. Remove motor and replace damaged motor mounts.</li> <li>2. Replace housing/unit as necessary.</li> </ol>
Unit runs but vibrates excessively.	<ol style="list-style-type: none"> <li>1. Severe jolt has bent motor shaft causing unit to be out of balance.</li> <li>2. Fan blade damaged.</li> <li>3. Dirt build up on one side of fan blade.</li> </ol>	<ol style="list-style-type: none"> <li>1. Remove and replace motor. Replace fan blade if necessary.</li> <li>2. Replace fan blade.</li> <li>3. Clean fan blade.</li> </ol>
Unit runs but fan does not turn.	<ol style="list-style-type: none"> <li>1. Fan is jammed against housing.</li> <li>2. Capacitor wire has broken/come loose, capacitor has failed.</li> <li>3. Housing has been damaged such that it presses on the fan blade.</li> </ol>	<ol style="list-style-type: none"> <li>1. Remove motor and replace damaged motor mounts. Replace fan blade if necessary.</li> <li>2. Repair/replace wires/capacitor as necessary.</li> <li>3. Replace housing/unit as necessary.</li> </ol>
Unit runs briefly, then shuts off on overload.	<ol style="list-style-type: none"> <li>1. Motorbearings are failing, or motor has developed an internal electric fault.</li> <li>2. Intake grill and/or exhaust grill is obstructed.</li> <li>3. Excessive duct length.</li> </ol>	<ol style="list-style-type: none"> <li>1. Replace motor.</li> <li>2. Remove obstruction.</li> <li>3. Reduce duct length to recommended maximum.</li> </ol>



## Americ Corporation

785 Bonnie Lane  
 Elk Grove Village, IL 60007  
 Tel: (847) 364-4646 • (800) 364-4642  
 Fax: (847) 364-4695  
 Email: sales@americ.com  
 www.americ.com

U.K. BS# 'BS 3456 Approved'  
 Australia 'No. V95045 Approved'